



# CQ51 Pressure Switch CD51 Explosion-Protected Construction Pressure Switch

## OUTLINE

This pressure switch is a lower pressure setting, high-pressure resistance switches for the case where the difference between the setting pressure and the maximum pressure is large.

## FEATURES

- The high pressure resistance construction is assured.
- The material of both the body and the terminal box is aluminum die-casting, to minimize the weight. The cover is of threaded type and the removing work of the cover is easily performed.
- Setting and locking can be performed from the exterior without removing the cover.

\* In case of selecting pressure gauge, choose the pressure range which can be used in between 30 ~ 65% of full scale, so that the gauge can give its full capacity.

## SPECIFICATION 1

**Model:**

- CQ51 Drip-proof construction
- CD51 Explosion-proof (d2G4)

**Fluid:**

Gas or liquid

**Operating condition:**

CQ51  
Under the normal condition, where there is no inflammable gas or liquid which cause the ignition or explosion.

CD51

Hazardous area. The details refer to explanation column of explosion-protected construction.

**Mounting:**

Panel mounting, 2B pipe mounting

**Connection:**

G3/8B(PF), G1/2B(PF), Rc1/4(PT female), Rc1/2(PT female), R1/2(PT), 1/2NPT

\* For other connections, please contact us.

**Wetted parts material:**

Diaphragm 316st.st.  
Socket-flange 316st.st.

**Pressure range:**

0.005 ~ 0.1 → 0.04 ~ 0.4MPa(0.05 ~ 1 → 0.4 ~ 4kgf/cm<sup>2</sup>)

**Max. operating pressure:**

0.7 ~ 3.5MPa (7 ~ 35kgf/cm<sup>2</sup>)  
(Depending on model, range)

**Operating temperature:**

CQ51 20 ~ 60°C  
CD51 -5 ~ 40°C

**Accuracy:**

1%max.P

**Temperature coefficient:**

0.05%max.P/g

**Dead band:**

0.0025 ~ 0.02MPa or less(0.025 ~ 0.2kgf/cm<sup>2</sup>)  
(Depending on model, range or number of contact)

**Switch:**

Micro switch

**Number of contact:**

One contact or two contact  
(CQ51 is simultaneous operation)

**Setting system:**

External adjustment type With setting lock

**Outlet for electric wire:**

CQ51 Gland JIS 20a, JIS 20b, JIS 20c  
CD51 Conduit type or flame-proof packing type

**Case material-finishing:**

Aluminium alloy die casting (ADC12)-Gray

**Construction:**

CQ51 Drip-proof type (IP43)  
CD51 Outdoor type (IP54)

**Weight:**

CQ51 Approx. 7.7kg  
CD51 Approx. 7kg

## SPECIFICATION 2

Electric characteristics:

| Rating  |                 |                | Withstand voltage                                 | Insulation resistance                                  |
|---|-----------------|----------------|---|--|
|   | Load resistance | Inductive load |   |  |
| 125V AC   | 15A             | 15A            | 1500V AC<br><br>Between terminal and case 1minute | 500V DC<br>100MΩ over<br><br>Between terminal and case |
| 250V AC   | 15A             | 15A            |   |  |
| 125V DC   | 0.5A            | 0.05A          |   |  |
| 30V DC  | 2A              | 1A             |   |  |
| · Inductive load: Power factor more 0.4 (AC)<br>Time-contact 7ms or less (DC) |                 |                |   |  |

Pressure range & dead band·Max. operating pressure:

CQ51

| Pressure range MPa (kgf/cm <sup>2</sup> )<br>(Pressure setting range) | Dead band MPa(kgf/cm <sup>2</sup> ) |                                | Max. operating pressure MPa(kgf/cm <sup>2</sup> ) |
|---|-------------------------------------|--------------------------------|---|
|   | One contact                         | Two contact                    |   |
| 0.005 ~ 0.1 (0.05 ~ 1)  | 0.0025 or less (0.025 or less)      | 0.0035 or less (0.035 or less) | 0.7 (7)   |
| 0.02 ~ 0.2 (0.2 ~ 2)  | 0.006 or less (0.06 or less)        | 0.009 or less (0.09 or less)   | 3 (30)  |
| 0.04 ~ 0.4 (0.4 ~ 4)  | 0.014 or less (0.14 or less)        | 0.02 or less (0.2 or less)     | 2.1 (21)  |

Note:In case of two contact type, it rises with correspondence of simultaneous operation.

CD51

| Pressure range MPa(kgf/cm <sup>2</sup> )<br>(Pressure setting range) | Dead band MPa(kgf/cm <sup>2</sup> ) |                               | Max. operating pressure MPa(kgf/cm <sup>2</sup> ) |
|--|-------------------------------------|-------------------------------|---|
|  | One contact                         | Two contact                   |   |
| 0.005 ~ 0.1 (0.05 ~ 1)   | 0.003 or less(0.03 or less)         | 0.0035 or less(0.035 or less) | 1 (10)  |
| 0.02 ~ 0.2 (0.2 ~ 2)   | 0.006 or less(0.06 or less)         | 0.009 or less(0.09 or less)   | 2 (20)  |
| 0.04 ~ 0.4 (0.4 ~ 4)   | 0.014 or less(0.14 or less)         | 0.02 or less(0.2 or less)     | 3.5 (35)  |

# DIMENSIONS

CQ51

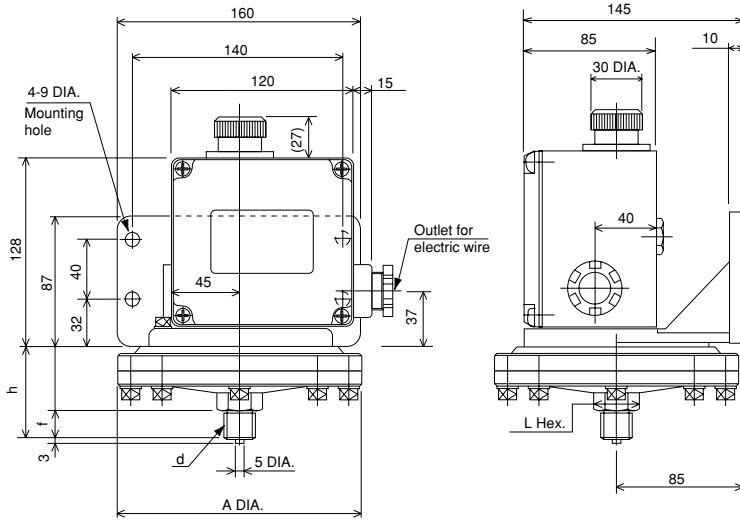

| Pressure range MPa (kgf/cm <sup>2</sup> ) | d                   | h      | f* | L Hex. | A DIA. |
|---|---------------------|--------|----|--------|--------|
| 0.005 ~ 0.1 (0.05 ~ 1)                    | G3/8B               | (57)   | 18 | 19     | 160    |
|   | G1/2B, R1/2, 1/2NPT | (59)   | 20 | 24     |        |
|   | Rc1/4               | (47)   | —  | 19     |        |
| 0.02 ~ 0.2 (0.2 ~ 2)                      | G3/8B               | (63)   | 18 | 19     | 150    |
|   | G1/2B, R1/2, 1/2NPT | (65)   | 20 | 24     |        |
|   | Rc1/4               | (53)   | —  | 19     |        |
| 0.04 ~ 0.4 (0.4 ~ 4)                      | G3/8B               | (59.5) | 18 | 19     | 120    |
|   | G1/2B, R1/2, 1/2NPT | (61.5) | 20 | 24     |        |
|   | Rc1/4               | (49.5) | —  | 19     |        |

\* G3B only

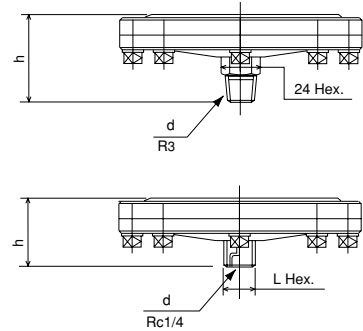

CD51

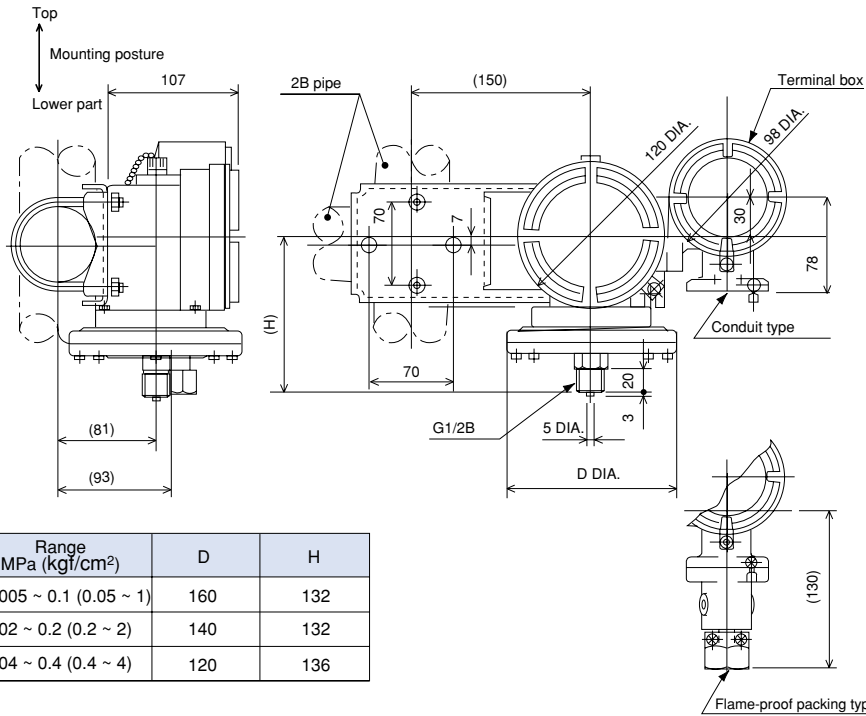

| Range MPa (kgf/cm <sup>2</sup> ) | D   | H   |
|----------------------------------|-----|-----|
| 0.005 ~ 0.1 (0.05 ~ 1)           | 160 | 132 |
| 0.02 ~ 0.2 (0.2 ~ 2)             | 140 | 132 |
| 0.04 ~ 0.4 (0.4 ~ 4)             | 120 | 136 |

# WIRING

CQ51

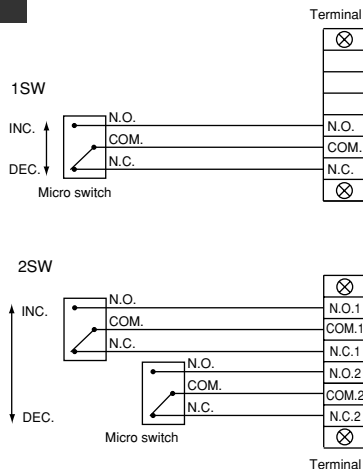

CD51

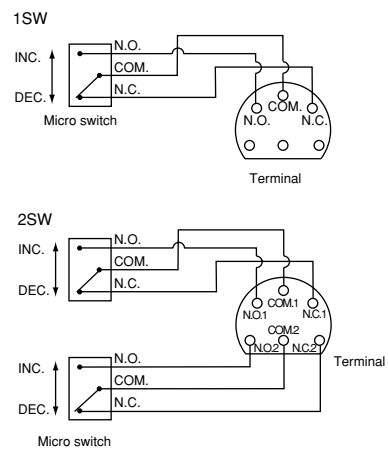

## EXPLOSION-PROOF

### Explosion-protected construction:

Explosion protected-construction is a totally enclosed construction such that even if the explosive gas explodes inside the container, the container withstands the force of the explosion and there is no danger of ignition of external explosive gases. Our pressure transmitter manufactured under this basic policy are widely used in the measurement, alarm, and control of pressure in factories and business offices where combustible gases or the vapor of combustible liquids having a flash point of 40°C or less may exist.

### Application range:d2G4

Explosion-protected construction:d

Explosion class:2 (Minimum gap with 25mm length of patch which permits the flame propagation:0.4mm to 0.6mm)

Ignitability:G4 (Ignition point:135°C to 200°C, limits of temperature rise:70 deg)

Hazardous areas:Zone 1 or zone 2

Objective industries:Petrochemical, chemical fibersynthetic resin, ethylene, methanol, dielectric products manufacturing, liquefied gas, electric furnace, pharmaceuticals, paints, ammonium sulfate, soda, other which there is the danger of ignition and explosion.

### Classification of hazardous areas:

| Hazardous areas | Contents  |
|-----------------|---|
| Zone 0          | A place where hazardous atmosphere is continuously present or present for a long period under ordinary circumstances. |
| Zone 1          | A place where hazardous atmosphere is likely to occur under ordinary circumstances.                                   |
| Zone 2          | A place where hazardous atmosphere is likely to occur under abnormal circumstances.                                   |

Registered model for labor ministry inspection and approval number: (CD51)

Registered model for labor ministry inspection:

CD50-2

Approval number for labor ministry inspection:

No.25230

It is official approval number to represent that explosion-protected construction pressure switch conformed to explosion proof standard. It is national official approval which is examined and authorized by technology institution of industrial safety.

## METHODS OF LEADING EXTERNAL CONDUCTORS AND CABLE IN TO A TERMINAL BOX

### Conduit type

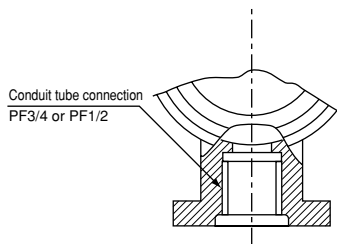

### Flame-proof packing type

| Packing inside (d) DIA. | Application cable out side DIA. | Protection tube connection             |
|-------------------------|---------------------------------|--|
| 10.5                    | 9.4                             | PF <sup>1/2</sup><br>PF <sup>3/4</sup> |
|                         | 9.9                             |  |
|                         | 10.1                            |  |
| 12                      | 10.5                            |  |
|                         | 11.0                            |  |
|                         | 11.5                            |  |
| 14                      | 11.9                            | PF <sup>3/4</sup><br>PF1               |
|                         | 12.0                            |  |
|                         | 12.5                            |  |
|                         | 12.6                            |  |
| 15.5                    | 13.1                            |  |
|                         | 13.5                            |  |
|                         | 13.6                            |  |
| 16.5                    | 14.5                            |  |
|                         | 15.6                            |  |

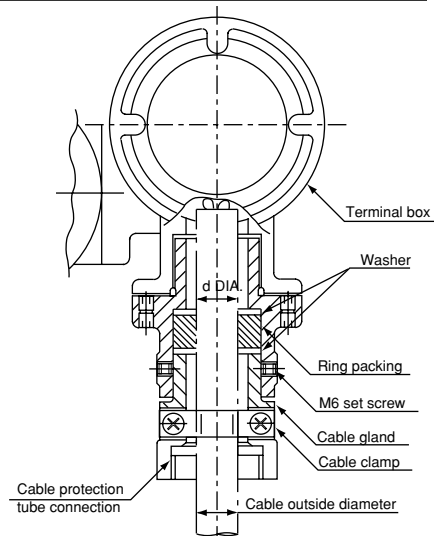

## REMARKS

- As a sequencer input; Use this switch in the ventilated condition. Otherwise the following might be caused. The contact resistance of the microswitch increases gradually as time passes. For the application in the atmosphere, especially including Si, SiO<sub>2</sub> will be accumulated on the contact part as switch operated. Then the contact resistance will be increased, so that switch may be not operated. Therefore, above is suggested for the application condition, including Si atmosphere. When you use this switch as sequencer input for controlling, input or connect through 100V AC Relay.
- Installation of protection circuit for contact In the inductive load open and close circuit, install the protection circuit to protect the contact. When you use the relay, choose the built-in protection circuit for the contact.

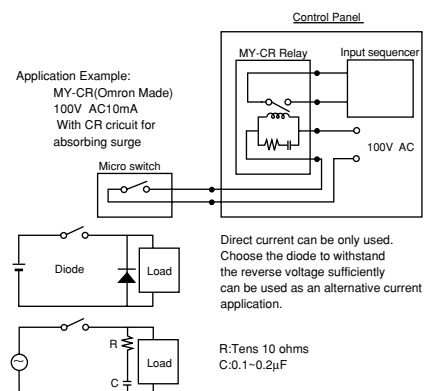

# Type No. constitution

Please specify Type No., each specification and range when ordering.

Note: For this Model, there is no applicable item for the figures X, but please specify X when ordering.

|   |   |   |   |                         |
|---|---|---|---|-------------------------|
| C | Q | 5 | 1 | Drip-proof construction |
| C | D | 5 | 1 | Explosion-proof         |

Model

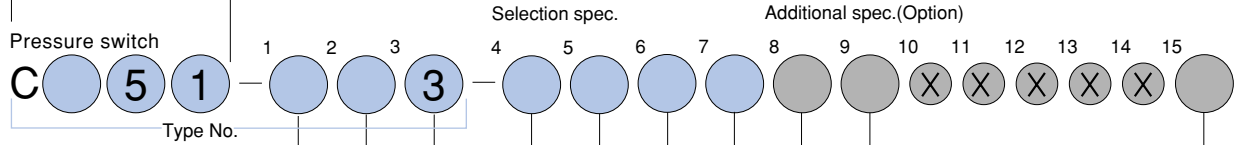

Type No.

In case of CQ51  
1 Mounting (Construction)

|   |                             |
|---|-----------------------------|
| 3 | Drip-proof type one contact |
| 4 | Drip-proof type two contact |

In case of CD51  
1 Mounting  
(Methods of leading external conductors and cable in to a terminal box.)

|   |   |
|---|---|
| 1 | One contact, panel mounting, conduit type               |
| 2 | Two contact, panel mounting, conduit type               |
| 3 | One contact, panel mounting, flame-proof packing type   |
| 4 | Two contact, panel mounting, flame-proof packing type   |
| 5 | One contact, 2B pipe mounting, conduit type             |
| 6 | Two contact, 2B pipe mounting, conduit type             |
| 7 | One contact, 2B pipe mounting, flame-proof packing type |
| 8 | Two contact, 2B pipe mounting, flame-proof packing type |

2 Connection

|   |                   |
|---|-------------------|
| 3 | G3/8B (CQ51 only) |
| 4 | G1/2B             |
| 7 | Rc1/4             |
| 9 | Rc1/2 (CD51 only) |
| H | R1/2              |
| M | 1/2NPT            |

3 Wetted parts material

|   |  |
|---|--|
| 3 | Diaphragm: 316st.st.<br>Socket-Flange: 316st.st.<br>Packing: NBR |
|---|--|

4 Pressure range (MPa)

(When ordering, please specify pressure range & unit.)

|   |             |
|---|-------------|
| 1 | 0.005 ~ 0.1 |
| 2 | 0.02 ~ 0.2  |
| 3 | 0.04 ~ 0.4  |

5 Type of contact

|   |   |
|---|---|
| 1 | H : Upper limit type with one contact                               |
| 2 | L : Lower limit type with one contact                               |
| 4 | 2H : Upper limit type with two contact (CD51)                       |
| 5 | 2L : Lower limit type with two contact (CD51)                       |
| I | WH: Simultaneous operation upper limit type with two contact (CQ51) |
| J | WL: Simultaneous operation lower limit type with two contact (CQ51) |

Additional spec. (Option)

9 Other additional spec.

|   |   |
|---|---|
| 0 | Nil   |
| 1 | Please specify your requirement<br>Case finishing |

8 Treatment

|   |                  |
|---|------------------|
| 0 | Nil              |
| 1 | Use no oil       |
| 2 | Use no water     |
| 3 | Use no oil-water |

In case of CQ51

7 Outlet for electric wire (Gland)

|   |         |
|---|---------|
| 6 | JIS 20a |
| 7 | JIS 20b |
| 8 | JIS 20c |

In case of CD51

7 Outlet for electric wire In case of conduit type

|   |                         |
|---|-------------------------|
| 2 | PF1/2 female            |
| 3 | PF3/4 female (Standard) |
| 4 | PF1 female              |

7 Outlet for electric wire

In case of flame-proof packing type

|   |                     |
|---|---------------------|
| 0 | PF1/2 female × 10.5 |
| 1 | PF1/2 female × 12   |
| 2 | PF3/4 female × 10.5 |
| 3 | PF3/4 female × 12   |
| 4 | PF3/4 female × 14   |
| 5 | PF3/4 female × 15.5 |
| 6 | PF3/4 female × 16.5 |
| 7 | PF1 female × 14     |
| 8 | PF1 female × 15.5   |
| 9 | PF1 female × 16.5   |

6 Switch

|   |   |
|---|---|
| 0 | Standard type   |
| 1 | Ultra high sensitivity switch (CD51 only)             |
| 3 | Standard+gold plated                                  |
| 4 | Ultra high sensitivity switch+gold plated (CD51 only) |

15 Document

|   |   |
|---|---|
| 0 | Nil   |
| 1 | Please specify your requirement<br>Drawing one sheet, Instruction manual, Inspection procedure, Mill sheet, Test report |